

INSTALLATION INSTRUCTIONS FREESTANDING LIGHT DUTY SIGNS



Freestanding Light Duty Signs ship partially assembled from the factory. Installation instructions include instructions on changing inserts.

Parts included:

- 1 – Two Sided Sign/Post assembly
- 4 – 290000645-001 Screw STOHP #8-32x1/2 BK (assembled into sign/post assembly and left and right feet)
- 2 – 290000644-001 Screw TCOHP #8-32x1 1/4 BK (assembled thru sign/post assembly and into base frame)
- 2 – Light Duty Freestanding Feet (with non-skid rubber pads)

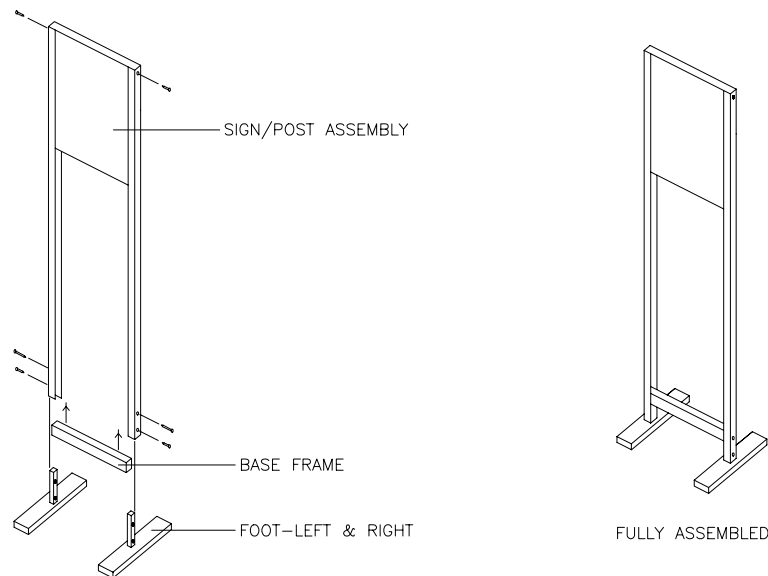

Assembly Instructions:

1. Remove base frame from sign/post assembly using a Phillips screwdriver.
2. Remove screws in left and right feet and attach each foot to inside of both posts using (2) short screws into the lower hole with a Phillips screwdriver. Note offset of the foot base plate to be on the outside of the posts.
3. Attach base frame using the (2) longer screws with a Phillips Screwdriver. Screw passes through upper hole in left and right foot and threads into the base frame.

Changing inserts:

1. Remove top screws on the legs with a Phillips screwdriver.
2. Slide rail up and out of the post assembly.
3. Remove and replace inserts by sliding them along the structural rail.
4. Slide rail into post assembly and reattach screws with a Phillips screwdriver.

If there are any questions, please contact our Technical Support Department at 800.777.4310.

IMPORTANT: Prior to installation, remove all contents from box and inspect each sign for damage. Box should contain signs, hardware, and mounting instructions for each style of mount used. Surface of the sign must be handled with care. Clean with water and mild detergent.

Customer is responsible for suitability of each mounting option. Testing is recommended prior to each use.

Rev. 03/14/07