

Specifications:

Decal Size: 12x12
Colors: Black, White, Red, Yellow

Project: *
Cust. Name: *
Date: 05/12/20
Revision Date: 00/00/00
Approved by: _____

 Name
 Date

ADA/ANSI Standards for signage disclaimer*: ADA/ANSI Applies Doesn't Apply Compliant Non-Compliant

Illustration:



Notes:

2105 Avery Vinyl - 3.1 mil with a long term removable adhesive
 4.75 mil Skid Resistant Overlaminat
 6 month durability

*Guideline per 2/90's interpretation of ADA/ANSI A17.1-200.3. Due to the ADA/ANSI's wide interpretation and other factors that may exist, 2/90 cannot affirm compliance in all situations and is hereby removed from responsibility regarding these issues.

Order:

Complete this order form and Fax to 2/90 at: 616.656.4300
Indicate quantity in boxes below.
 Print desired copy above or attach copy schedule.
 Designate Mount Option if ordering a full sign.

Name: _____
Phone: _____
Fax: _____
Date: _____



Grand Rapids, MI 49512
 800-777-4310 www.290signs.com

Full Sign	
Qty.	Mount Option:

Specifications:

Decal Size: 12x12
Colors: Black, White, Red, Yellow

Project: *
Cust. Name: *
Date: 05/12/20
Revision Date: 00/00/00
Approved by: _____

Name _____
 Date _____

ADA/ANSI Standards for signage disclaimer*: ADA/ANSI Applies Doesn't Apply Compliant Non-Compliant

Illustration:



Notes:

Exterior 2105 Avery Vinyl - 3.1 mil with a long term removable adhesive
 4.75 mil Skid Resistant Overlaminated
 6 month durability

*Guideline per 2/90's interpretation of ADA/ANSI A17.1-200.3. Due to the ADA/ANSI's wide interpretation and other factors that may exist, 2/90 cannot affirm compliance in all situations and is hereby removed from responsibility regarding these issues.

Order:

Complete this order form and Fax to 2/90 at: 616.656.4300
Indicate quantity in boxes below.
 Print desired copy above or attach copy schedule.
 Designate Mount Option if ordering a full sign.

Name: _____
Phone: _____
Fax: _____
Date: _____



Grand Rapids, MI 49512
 800-777-4310 www.290signs.com

Full Sign	
Qty.	Mount Option:

Specifications:

Decal Size: 17-1/4x17-1/4
Colors: Black, White, Red, Yellow

Project: *
Cust. Name: *
Date: 05/12/20
Revision Date: 00/00/00
Approved by: _____

 Name
 Date

ADA/ANSI Standards for signage disclaimer*: ADA/ANSI Applies Doesn't Apply Compliant Non-Compliant

Illustration:

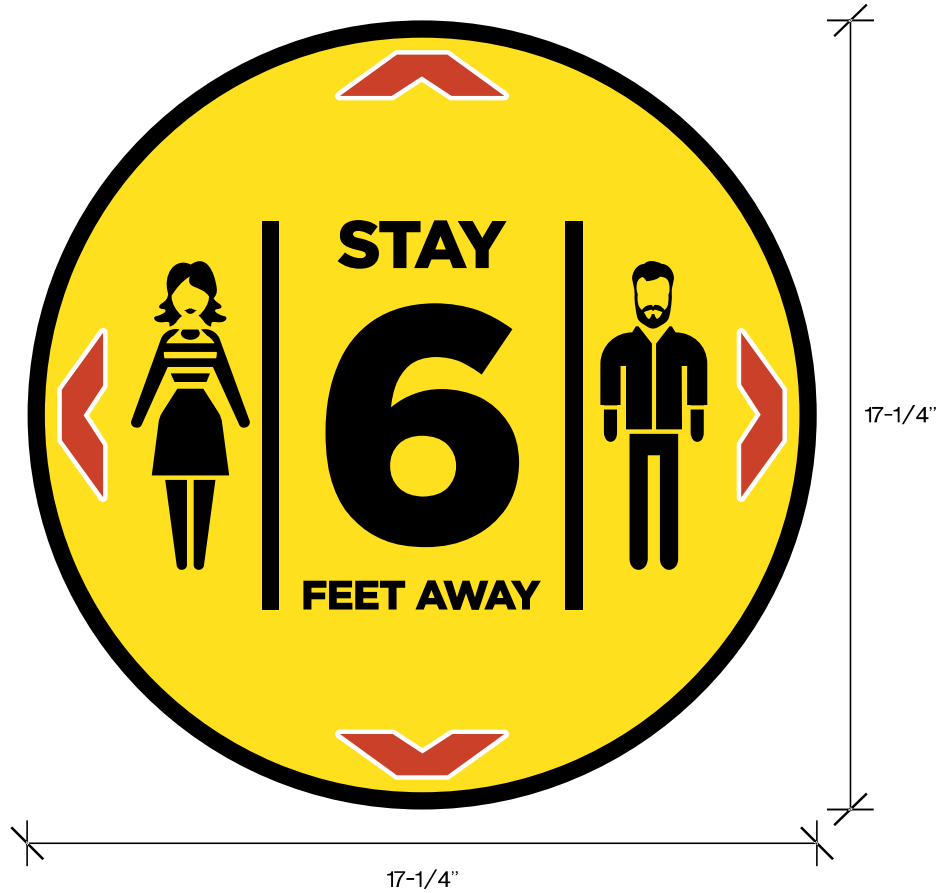

Notes:

2105 Avery Vinyl - 3.1 mil with a long term removable adhesive
 4.75 mil Skid Resistant Overlaminat
 6 month durability

*Guideline per 2/90's interpretation of ADA/ANSI A17.1-200.3. Due to the ADA/ANSI's wide interpretation and other factors that may exist, 2/90 cannot affirm compliance in all situations and is hereby removed from responsibility regarding these issues.

Order:

Complete this order form and Fax to 2/90 at: 616.656.4300
Indicate quantity in boxes below.
 Print desired copy above or attach copy schedule.
 Designate Mount Option if ordering a full sign.

Name: _____
Phone: _____
Fax: _____
Date: _____



Grand Rapids, MI 49512
 800-777-4310 www.290signs.com

Full Sign	
Qty.	Mount Option:

Specifications:

Decal Size: 17-1/4x17-1/4
Colors: Black, White, Red, Yellow

Project: *
Cust. Name: *
Date: 05/12/20
Revision Date: 00/00/00
Approved by: _____

 Name
 Date

ADA/ANSI Standards for signage disclaimer*: ADA/ANSI Applies Doesn't Apply Compliant Non-Compliant

Illustration:

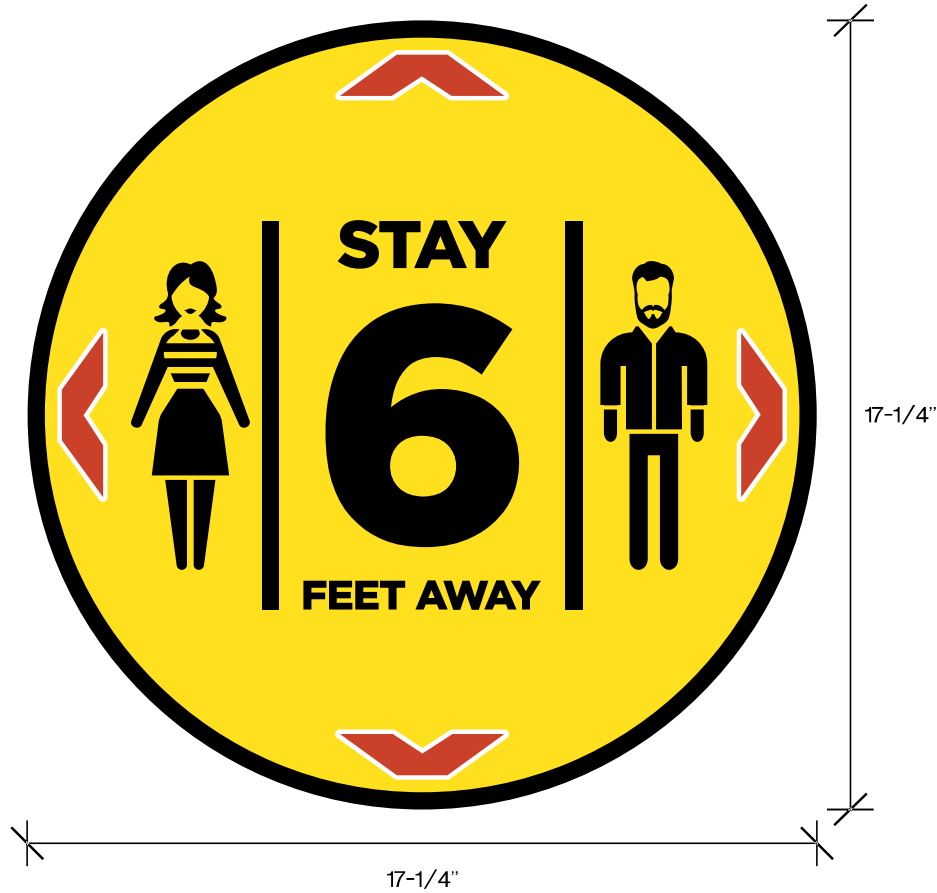

Notes:

Exterior 2105 Avery Vinyl - 3.1 mil with a long term removable adhesive
 4.75 mil Skid Resistant Overlaminated
 6 month durability

*Guideline per 2/90's interpretation of ADA/ANSI A17.1-200.3. Due to the ADA/ANSI's wide interpretation and other factors that may exist, 2/90 cannot affirm compliance in all situations and is hereby removed from responsibility regarding these issues.

Order:

Complete this order form and Fax to 2/90 at: 616.656.4300
Indicate quantity in boxes below.
 Print desired copy above or attach copy schedule.
 Designate Mount Option if ordering a full sign.

Name: _____
Phone: _____
Fax: _____
Date: _____



Grand Rapids, MI 49512
 800-777-4310 www.290signs.com

Full Sign	
Qty.	Mount Option:

Specifications:

Decal Size: 24x36
Colors: Black, White, Red, Yellow

Project: *
Cust. Name: *
Date: 05/12/20
Revision Date: 00/00/00
Approved by: _____

Name _____
 Date _____

ADA/ANSI Standards for signage disclaimer*: ADA/ANSI Applies Doesn't Apply Compliant Non-Compliant

Illustration:



Notes: 2105 Avery Vinyl - 3.1 mil with a long term removable adhesive
 4.75 mil Skid Resistant Overlaminated
 6 month durability

*Guideline per 2/90's interpretation of ADA/ANSI A17.1-200.3. Due to the ADA/ANSI's wide interpretation and other factors that may exist, 2/90 cannot affirm compliance in all situations and is hereby removed from responsibility regarding these issues.

Order: Complete this order form and Fax to 2/90 at: 616.656.4300
Indicate quantity in boxes below.
 Print desired copy above or attach copy schedule.
 Designate Mount Option if ordering a full sign.

Full Sign	
Qty.	Mount Option:

Name: _____
 Phone: _____
 Fax: _____
 Date: _____



Grand Rapids, MI 49512
 800-777-4310 www.290signs.com

Specifications:

Decal Size: 24x36
Colors: Black, White, Red, Yellow

Project: *
Cust. Name: *
Date: 05/12/20
Revision Date: 00/00/00
Approved by: _____

Name _____
 Date _____

ADA/ANSI Standards for signage disclaimer*: ADA/ANSI Applies Doesn't Apply Compliant Non-Compliant

Illustration:



Notes:

Exterior 2105 Avery Vinyl - 3.1 mil with a long term removable adhesive
 4.75 mil Skid Resistant Overlaminated
 6 month durability

*Guideline per 2/90's interpretation of ADA/ANSI A17.1-200.3. Due to the ADA/ANSI's wide interpretation and other factors that may exist, 2/90 cannot affirm compliance in all situations and is hereby removed from responsibility regarding these issues.

Order:

Complete this order form and Fax to 2/90 at: 616.656.4300
Indicate quantity in boxes below.
 Print desired copy above or attach copy schedule.
 Designate Mount Option if ordering a full sign.

Name: _____
Phone: _____
Fax: _____
Date: _____



Grand Rapids, MI 49512
 800-777-4310 www.290signs.com

Full Sign	
Qty.	Mount Option:

Specifications:

Sign Size: 9x11
 Mount Option: A-Adhesive
 Backer Color: 704 Black

Project: *
 Cust. Name: *
 Date: 05/06/20
 Revision Date: 00/00/00
 Approved by: _____

Name _____
 Date _____

Insert A
 Locking: No
 Insert Size: 9x11w
 Insert Color: 704 Black, 408 White
 Copy Option: Laser Print
 Copy Style: *
 Copy Size: *
 Copy Color: *
 Copy Position: *

Insert B
 Locking: *
 Insert Size: *
 Insert Color: *
 Copy Option: *
 Copy Style: *
 Copy Size: *
 Copy Color: *
 Copy Position: *

Insert C
 Locking: *
 Insert Size: *
 Insert Color: *
 Copy Option: *
 Copy Style: *
 Copy Size: *
 Copy Color: *
 Copy Position: *

ADA/ANSI Standards for signage disclaimer*: ADA/ANSI Applies Doesn't Apply Compliant Non-Compliant

Illustration:



Notes: Window to hold 8-1/2"x11" paper.

*Guideline per 2/90's interpretation of ADA/ANSI A117.1-200.3. Due to the ADA/ANSI's wide interpretation and other factors that may exist, 2/90 cannot affirm compliance in all situations and is hereby removed from responsibility regarding these issues.

Order: Complete this order form and Fax to 2/90 at: 616.656.4300
 Indicate quantity in boxes below.
 Print desired copy above or attach copy schedule.
 Designate Mount Option if ordering a full sign.

Name: _____
 Phone: _____
 Fax: _____
 Date: _____

Full Sign		Replacement Inserts					
Qty.	Mount Option:	A Qty.	B Qty.	C Qty.	D Qty.	E Qty.	F Qty.



Grand Rapids, MI 49512
 800-777-4310 www.290signs.com

Specifications:

Sign Size: 12x8-1/2
 Mount Option: A-Adhesive
 Backer Color: 704 Black

Project: *
 Cust. Name: *
 Date: 05/04/20
 Revision Date: 05/05/20, 05/06/20
 Approved by: _____ Name
 _____ Date

Insert A
 Locking: No
 Insert Size: 12x8-1/2w
 Insert Color: 704 Black, 408 White
 Copy Option: Laser Print
 Copy Style: *
 Copy Size: *
 Copy Color: *
 Copy Position: *

Insert B
 Locking: *
 Insert Size: *
 Insert Color: *
 Copy Option: *
 Copy Style: *
 Copy Size: *
 Copy Color: *
 Copy Position: *

Insert C
 Locking: *
 Insert Size: *
 Insert Color: *
 Copy Option: *
 Copy Style: *
 Copy Size: *
 Copy Color: *
 Copy Position: *

ADA/ANSI Standards for signage disclaimer*: ADA/ANSI Applies Doesn't Apply Compliant Non-Compliant

Illustration:

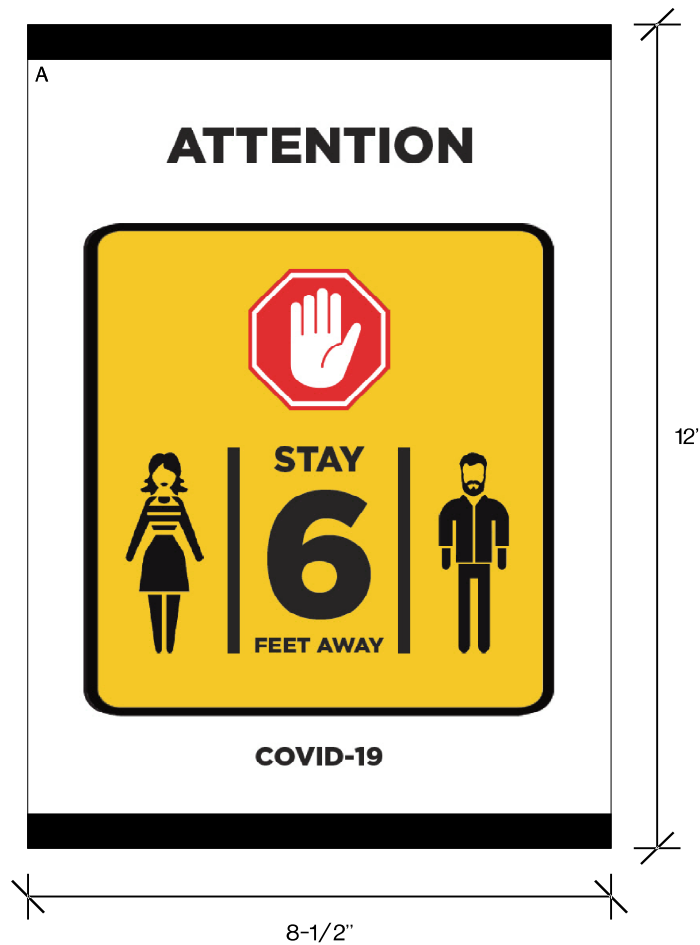

Notes: Window to hold 11"x8-1/2" paper.

*Guideline per 2/90's interpretation of ADA/ANSI A117.1-200.3. Due to the ADA/ANSI's wide interpretation and other factors that may exist, 2/90 cannot affirm compliance in all situations and is hereby removed from responsibility regarding these issues.

Order: Complete this order form and Fax to 2/90 at: 616.656.4300
Indicate quantity in boxes below.
 Print desired copy above or attach copy schedule.
 Designate Mount Option if ordering a full sign.

Name:
 Phone:
 Fax:
 Date:

Full Sign	
Qty.	Mount Option:

Replacement Inserts					
A Qty.	B Qty.	C Qty.	D Qty.	E Qty.	F Qty.



Grand Rapids, MI 49512
 800-777-4310 www.290signs.com

2/90 Arc Sign

A-FS - 11x8.5x48

Specifications:

Sign Size: 11x8-1/2
Mount Option: Freestanding Light Duty
Edge Rail Color: 101 Satin
Frame Color: 704 Black

Standard or Vertical Frame: Standard
Accent Strip Color (s): *

Project: *
Cust. Name: *
Date: 05/05/20
Revision Date: 05/06/20
Approved by: _____
 Name _____
 Date _____

Insert A
Insert Size: 11x8-1/2w
Insert Color: 704 Black, 408 White
Copy Option: Laser Print
Copy Style: *
Copy Size: *
Copy Color: *
Copy Position: *

Insert B
Insert Size: *
Insert Color: *
Copy Option: *
Copy Style: *
Copy Size: *
Copy Color: *
Copy Position: *

Insert C
Insert Size: *
Insert Color: *
Copy Option: *
Copy Style: *
Copy Size: *
Copy Color: *
Copy Position: *

ADA/ANSI Standards for signage disclaimer*: ADA/ANSI Applies Doesn't Apply Compliant Non-Compliant

Illustration:

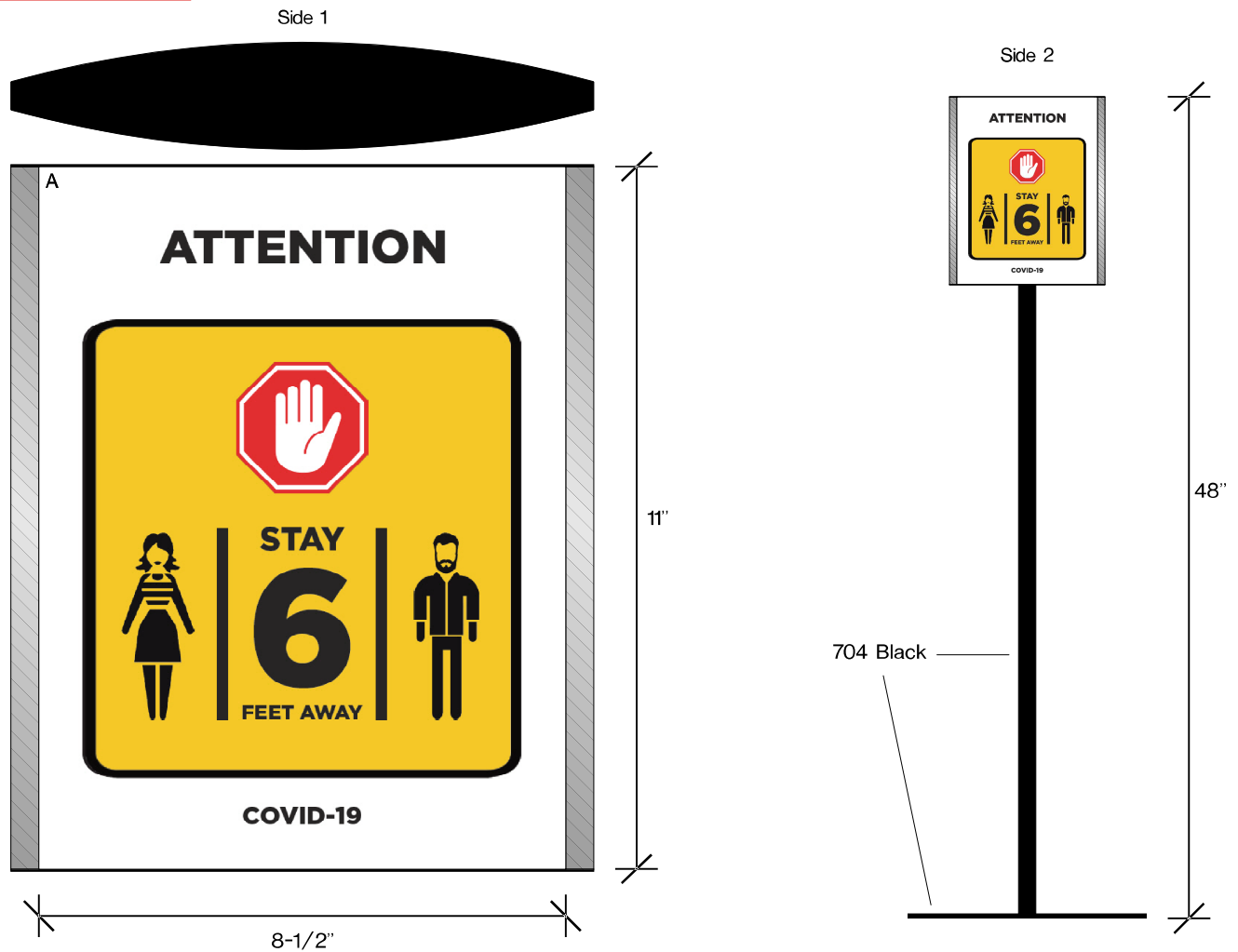

Notes:

Window to hold 11"x8-1/2" paper.

*Guideline per 2/90's interpretation of ADA/ANSI A117.1-200.3. Due to the ADA/ANSI's wide interpretation and other factors that may exist, 2/90 cannot affirm compliance in all situations and is hereby removed from responsibility regarding these issues.

Order:

Complete this order form and Fax to 2/90 at: 616.656.4300
Indicate quantity in boxes below.
 Print desired copy above or attach copy schedule.
 Designate Mount Option if ordering a full sign.

Name: _____
Phone: _____
Fax: _____
Date: _____



Grand Rapids, MI 49512
 800-777-4310 www.290signs.com

Full Sign		Replacement Inserts					
Qty.	Mount Option:	A Qty.	B Qty.	C Qty.	D Qty.	E Qty.	F Qty.

2/90 Protective Barriers

FSPB-SM - Small Freestanding Protective Barrier with Pass-Through

Specifications:

Barrier Size: 23-1/2x27
 Mount: Freestanding
 Material: Clear Acrylic

Project: *
 Cust. Name: *
 Date: 05/12/20
 Revision Date: 00/00/00
 Approved by: _____

Name _____
 Date _____

ADA/ANSI Standards for signage disclaimer*: ADA/ANSI Applies Doesn't Apply Compliant Non-Compliant

Illustration:

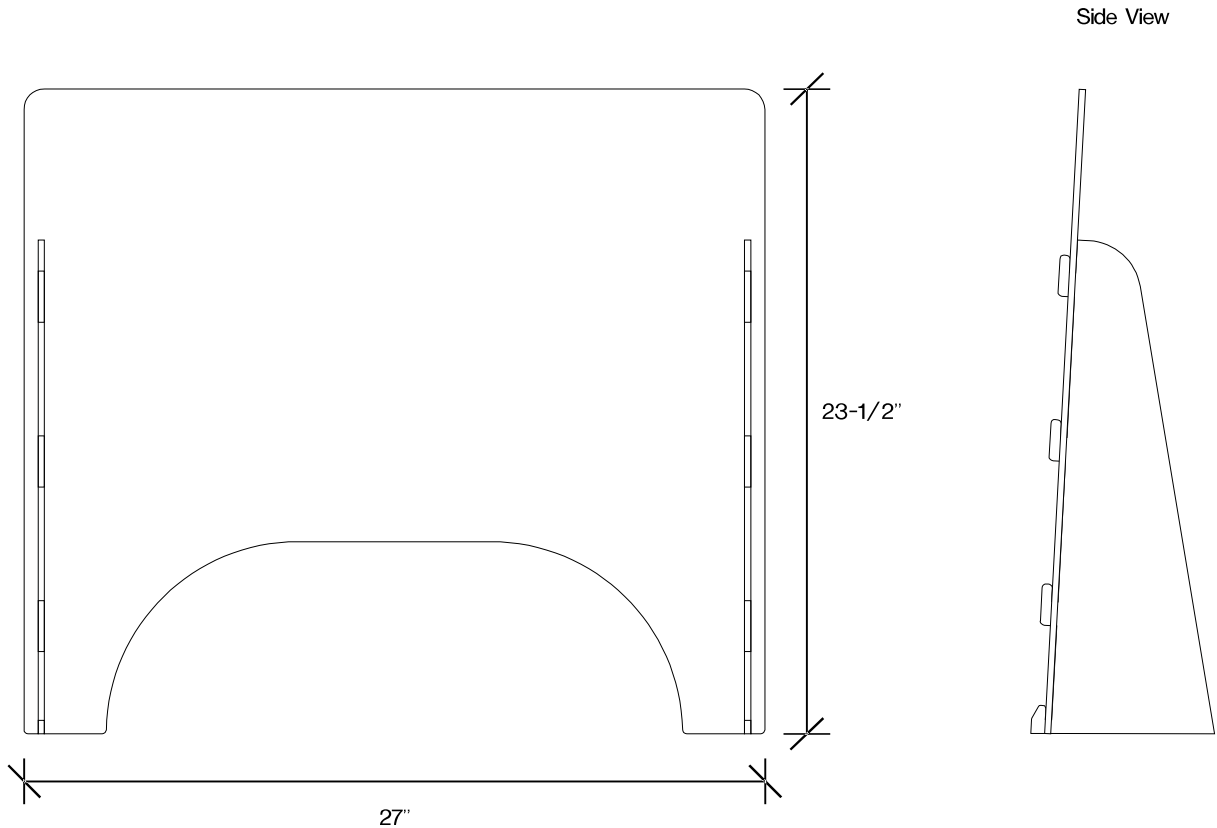

Notes:

*Guideline per 2/90's interpretation of ADA/ANSI A17.1-200.3. Due to the ADA/ANSI's wide interpretation and other factors that may exist, 2/90 cannot affirm compliance in all situations and is hereby removed from responsibility regarding these issues.

Order:

Complete this order form and Fax to 2/90 at: 616.656.4300
Indicate quantity in boxes below.
 Print desired copy above or attach copy schedule.
 Designate Mount Option if ordering a full sign.

Full Sign	
Qty.	Mount Option:

Name: _____
 Phone: _____
 Fax: _____
 Date: _____



Grand Rapids, MI 49512
 800-777-4310 www.290signs.com

2/90 Protective Barriers

FSPB-LG - Large Freestanding Protective Barrier with Pass-Through

Specifications:

Barrier Size: 30x36
 Mount: Freestanding
 Material: Clear Acrylic

Project: *
 Cust. Name: *
 Date: 05/12/20
 Revision Date: 00/00/00
 Approved by: _____

Name _____
 Date _____

ADA/ANSI Standards for signage disclaimer*: ADA/ANSI Applies Doesn't Apply Compliant Non-Compliant

Illustration:

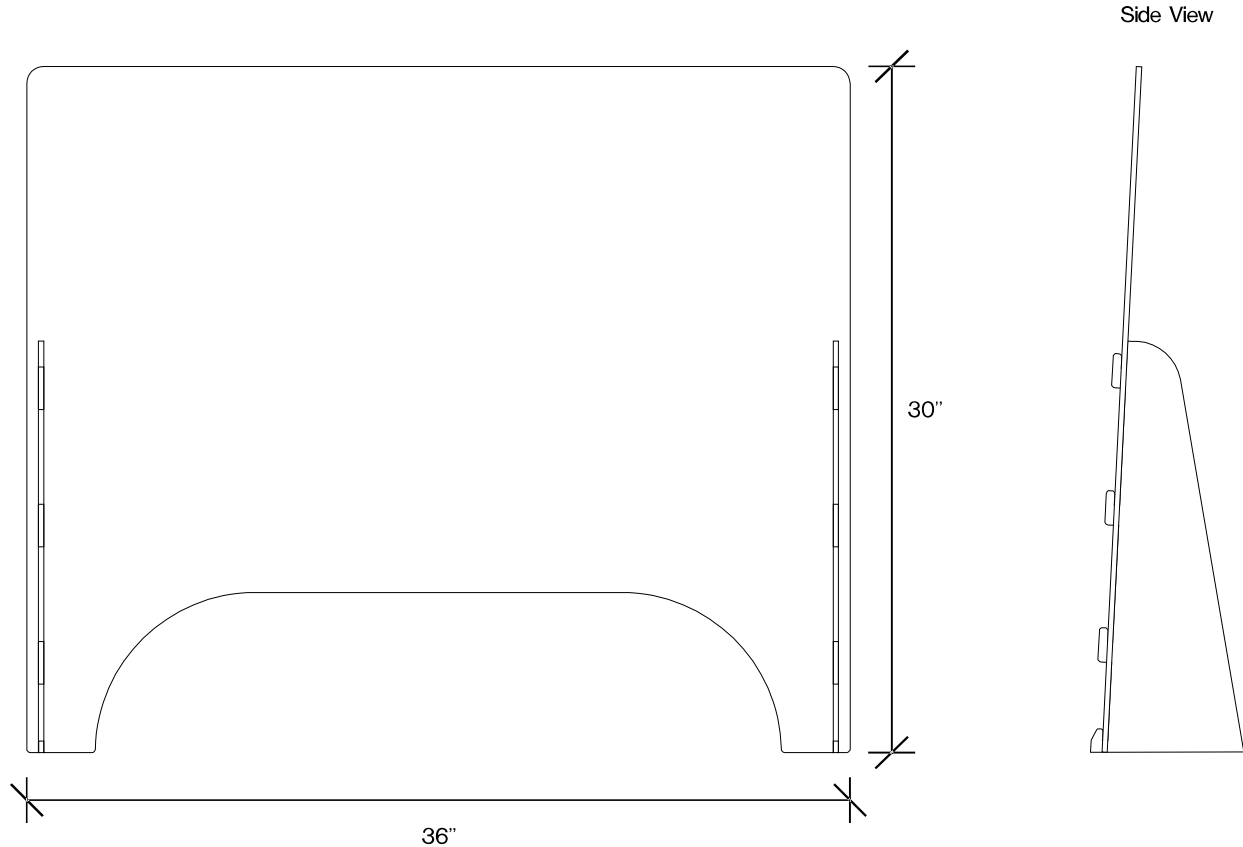

Notes:

*Guideline per 2/90's interpretation of ADA/ANSI A17.1-200.3. Due to the ADA/ANSI's wide interpretation and other factors that may exist, 2/90 cannot affirm compliance in all situations and is hereby removed from responsibility regarding these issues.

Order: Complete this order form and Fax to 2/90 at: 616.656.4300
Indicate quantity in boxes below.
 Print desired copy above or attach copy schedule.
 Designate Mount Option if ordering a full sign.

Full Sign	
Qty.	Mount Option:

Name: _____
 Phone: _____
 Fax: _____
 Date: _____



Grand Rapids, MI 49512
 800-777-4310 www.290signs.com

2/90 Protective Barriers

PMPB-SM - Panel Mount Protective Barrier

Specifications:

Barrier Size: 31-1/2x23-1/2
 Mount: Screw
 Material: Clear Acrylic

Project: *
 Cust. Name: *
 Date: 05/12/20
 Revision Date: 00/00/00
 Approved by: _____

Name _____
 Date _____

ADA/ANSI Standards for signage disclaimer*: ADA/ANSI Applies Doesn't Apply Compliant Non-Compliant

Illustration:

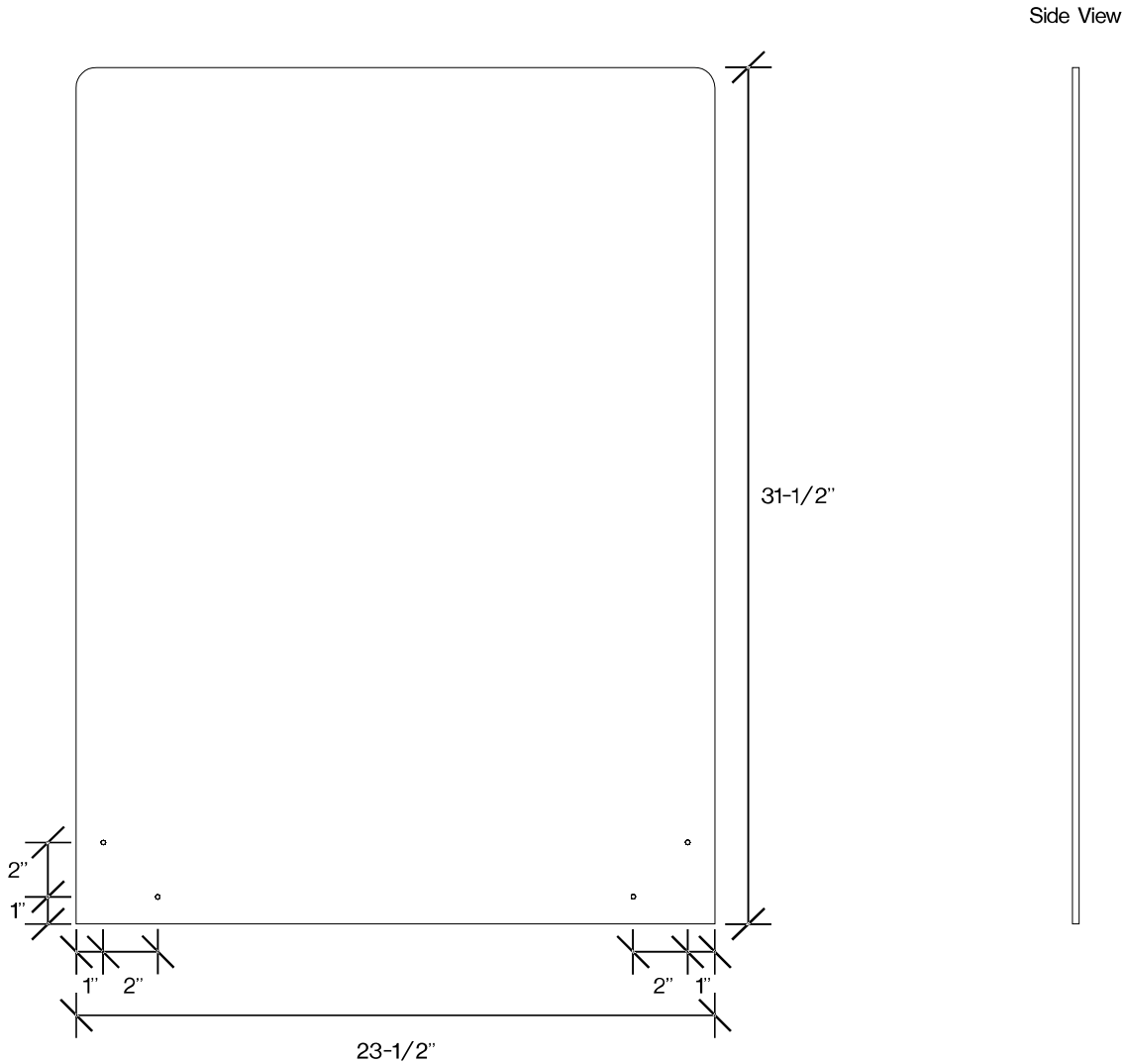

Notes:

*Guideline per 2/90's interpretation of ADA/ANSI A17.1-200.3. Due to the ADA/ANSI's wide interpretation and other factors that may exist, 2/90 cannot affirm compliance in all situations and is hereby removed from responsibility regarding these issues.

Order: Complete this order form and Fax to 2/90 at: 616.656.4300
Indicate quantity in boxes below.
 Print desired copy above or attach copy schedule.
 Designate Mount Option if ordering a full sign.

Full Sign	
Qty.	Mount Option:

Name: _____
 Phone: _____
 Fax: _____
 Date: _____



Grand Rapids, MI 49512
 800-777-4310 www.290signs.com